



12-Relay Softwired Contactor Panel with Integrated Outdoor Photocell Controller



DESCRIPTION

The RSWC12OUT-1 is a complete outdoor lighting control panel which uses the 12-relay TLC Softwired Contactor. It includes:

1. A factory-installed and pre-wired outdoor photocell controller (RPCON3-OUT)
2. A photocell head (RPSEN3-OUT) to be installed and connected at the job site
3. A 4-pole electrically-held lighting contactor for controlling 2-pole parking lot lighting, if required
4. A power-sensing relay (RIBU1C) to indicate when the kitchen lighting is on

The Softwired Contactor provides a simple way to group lighting circuits by function for both manual and automatic control. Used with the RPCON3-OUT outdoor photocell controller, lighting circuits for security, parking and signage can be grouped and controlled simply based on available daylight and whether or not the building is occupied.

The RSWC12OUT-1 has four separate channels. Each channel can control any combination of the 12 relays (lighting circuits). Channel switches within the panel provide built-in override capability. Two independent inputs per channel allow both the photocell controller and another input, such as a pilot switch, to control that group.

The RPCON3-OUT outdoor photocell controller comes mounted within the interior. The controller's three outputs for security lighting, parking and signage are pre-wired to the first three channels of the Softwired Contactor panel. The fourth channel is available for grouping other circuits.

CAUTION: Make sure all power is OFF before wiring. Do not energize wiring until the unit is fully assembled. Conform to all applicable codes.

INSTALLATION

1. Mount Panel

32 to 131°F (0 to 50°C), 10 to 95% relative humidity, stationary applications. The tub should be level, plumb and rigidly installed with hardware sufficient to hold 100 lbs. (48kg). The orientation should be as illustrated below.

2. Wire Line Voltage

Before making any connections to the relays or contactor, make sure that none of the load circuits are shorted or miswired. Wire from the circuit breaker through each relay's SPST output terminals, and from there to the loads. Wire the power supply. Relay #12 is pre-wired to the 4-pole lighting contactor. Wire 2-phase parking lot circuits through the contactor, if required.

3. Install Photocell Head Outdoors

Mount the RPSEN3-OUT photocell head on the building roof facing toward the northern sky as illustrated on the next page.

4. Wire Kitchen Light Sensor

Mount the RIBU1C sensing module on the kitchen light junction box (see illustration on next page) or onto the wiring compartment of a kitchen fixture. The YELLOW/WHITE striped wire connects to the neutral and the BLACK/WHITE striped wire to the switched hot leg (115VAC). Bring the low-voltage YELLOW and ORANGE leads out of the junction box through the strain relief provided.

5. Wire Low Voltage

(Refer to the illustration on the next page)

Photocell Head

Wire the photocell head to the "PHOTOCELL" input terminals on the RPCON3-OUT controller.

Occupied Contact

Connect the YELLOW and ORANGE low-voltage leads from the RIBU1C to the "OCCUPIED" contacts on the controller.

Signage Switch

Wire the signage pilot switch to the second set of Channel C inputs on the Softwired Contactor board.

6. Verify Photocell Controller Settings

Refer to instructions on controller label for setting footcandle levels for security, parking and signage lighting and for parking egress delay.

7. Power Up and Test Relays

Apply power to the power supply only. Press the Relay Control Button next to each relay's yellow plug-in termination to toggle it ON/OFF. The relay should "click" and the LED status indicator should change state. Confirm the operation by measuring the line-voltage terminations of each relay (and the 4-pole contactor, if necessary).

Apply power to the relays (and contactor). Being careful not to touch any line-voltage wiring, toggle each relay ON/OFF again and confirm that each controls the appropriate load.

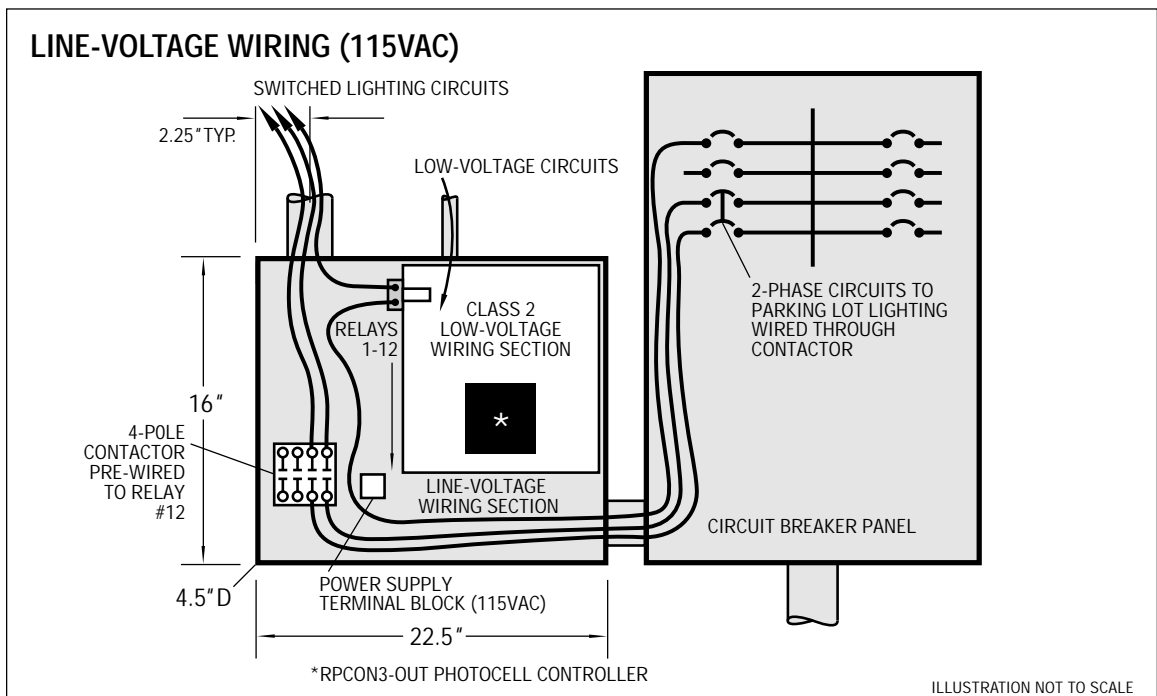

INSTALLATION

LOW-VOLTAGE CONTROL WIRING

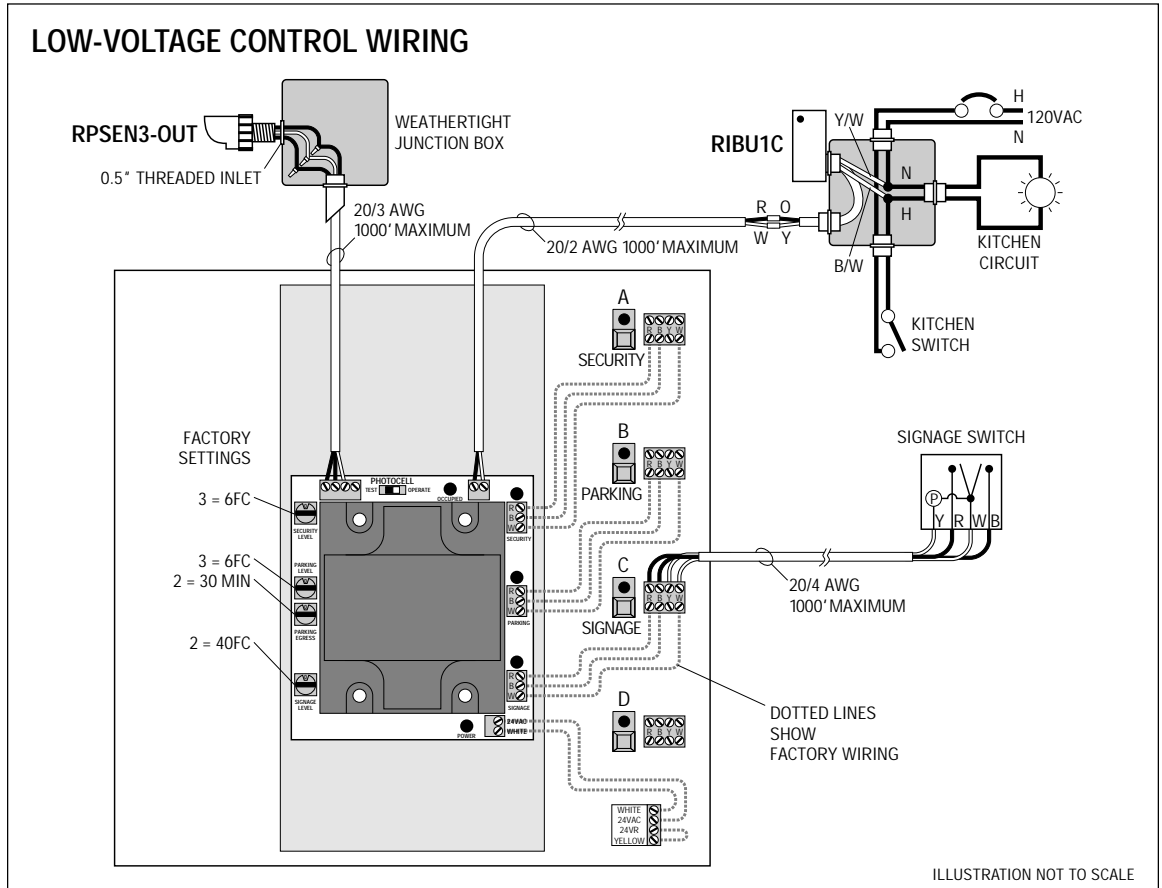

8. Document Wiring

Record the circuit controlled by each relay on the **Wiring Schedule** located on the back page of these installation instructions. Also indicate which relays are controlled by each channel. Place the Schedule in the plastic envelope and attach it to the inside of the panel cover.

9. Softwire Relay Groups to Channels

Following the instructions to the right, softwire relays to the appropriate channels:

Channel A: Security lighting

Channel B: Parking lot lighting (Note: Relay #12 controls the 4-pole contactor)

Channel C: Signage lighting

Channel D: Optional lighting

10. Test Operation

Test photocell responsiveness by sliding the "PHOTOCELL" switch to "TEST" and covering the photocell head. Return to normal operation by sliding the switch to "OPERATE". Test against the sequence of operations to ensure that all controls are operating as intended.

Softwiring a Relay Group to a Channel

- 1 Press and hold the Channel Push Button for several seconds. The channel LED and the LEDs for relays currently controlled by that input will begin to flash.
- 2 Select the relays to be controlled. The LED for each relay "softwired" to the channel input selected will be flashing ON/OFF. Press the associated Relay Control Button to add/delete that relay to/from the group.
- 3 Press the Channel Push Button again. The LEDs will stop flashing and the input switch will now control the relays selected.
- 4 Test. Press the Channel Push Button to toggle the group ON/OFF/ON. The input LED will track the last action. Now, turn OFF each relay in the group using the individual Relay Control Buttons. When the last relay is turned OFF, the channel LED should also go OFF.

Note: Check those relays which are controlled by each channel under that channel letter below.

WIRING SCHEDULE: 12-RELAY SOFTWIRED CONTACTOR

RELAY # CIRCUIT	SUPPLY	LOAD DESCRIPTION	RELAYS CONTROLLED BY EACH CHANNEL			
			A SECURITY	B PARKING	C SIGNAGE	D
1						
2						
3						
4						
5						
6						
7						
8						
9						
10						
11						
12		FOUR-POLE LIGHTING CONTACTOR				